

A_DT-GH_OBMKMQ_TB_ST_GEF-2FLG.PDF

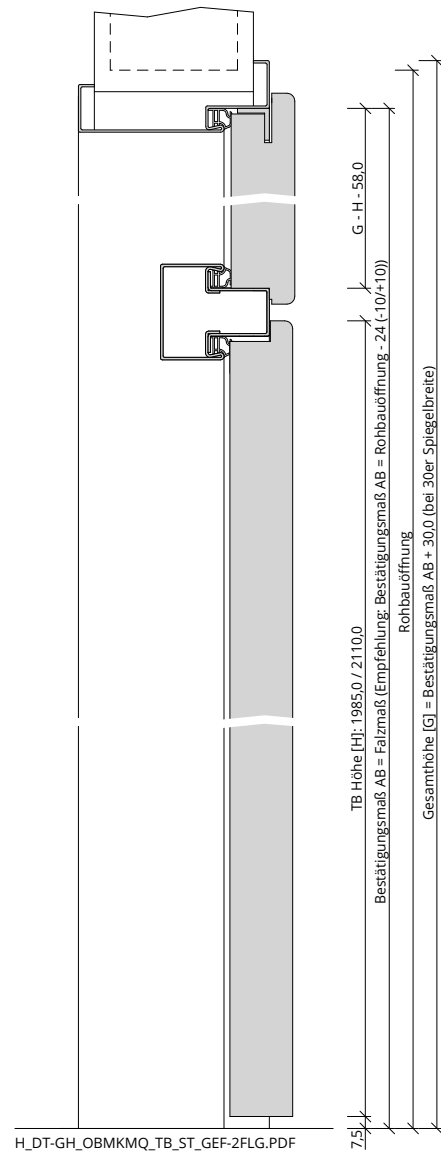

H_DT-GH_OBMKMQ_TB_ST_GEF-2FLG.PDF

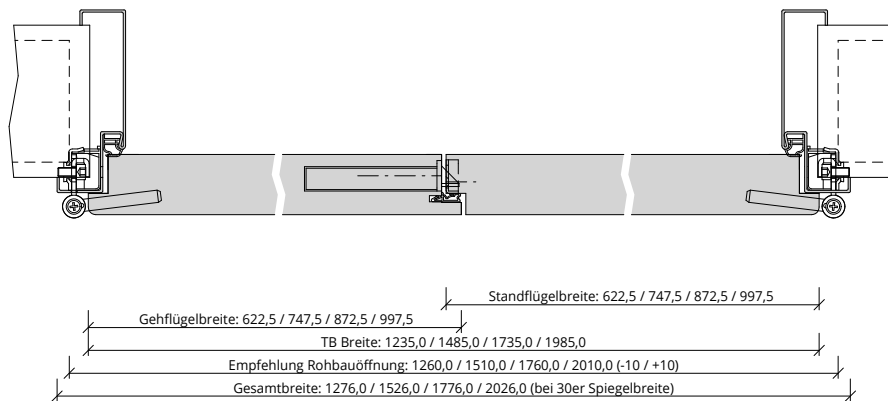

Q_DT-GH_OBMKMQ_TB_ST_GEF-2FLG.PDF

